

AHU-KIT ^{NEU}

TEILE UND FUNKTIONEN

- Anti-Kaltluft-Funktion wenn ein Außengerät abtaut
- Fehler Info. Ausgabe
- IP 44 zertifiziert wasserdicht, was Außenbetrieb ermöglicht

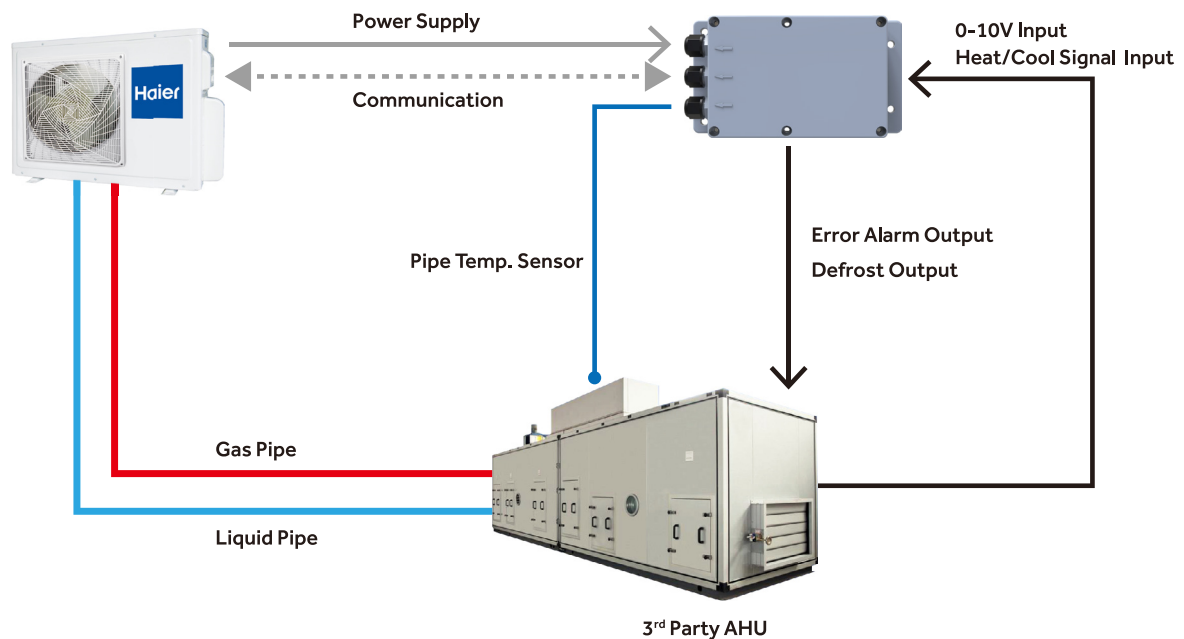

SPEZIFIKATION

MODELL	AH1-LCAC1	AH1-RAC1
Energiezufuhr(Ph/V/Hz)	1 Phase/220~240V/50/60Hz	1 Phase/220~240V/50/60Hz
Maße (B/Durchm./Höhe)mm	206/52.5/110	206/52.5/110
Paketmaße (B/Durchm./Höhe)mm	240/80/120	240/80/120
Farbe	Grau	Grau
Gewicht (KG)	0,4	0,4
Versandgewicht(KG)	0,6	0,6

Kompatibilität

MODELL	Produkte	AH1-LCAC1	AH1-RAC1
 <p>R32 Match Plus Heizpumpe</p>	1U25S2SM1FA-2		●
	1U35S2SM1FA-2		●
	1U42S2SM1FA		●
	1U50S2SJ2FA-2		●
	1U71S2ST1FA	●	
	1U105S2SS1FA	●	
	1U105S2SS2FA	●	
	1U105S2SS1FB	●	
	1U125S2SN2FA	●	
	1U125S2SN2FB	●	
	1U140S2SN1FA	●	
	1U140S2SN1FB	●	
	1U140S2SP2FA	●	
	1U140S2SP2FB	●	
	1U160S2SP1FB	●	