

Haier

More Creation, More Possibilities

Haier

Heating

Electric Water Heaters

—
Brochure 2026





Haier

Haier

More Creation, More Possibilities

Professional, Smart & Healthy Air Solutions Provider

OUR VISION

To be a globally recognised expert in smart and healthy Air Solutions.

OUR MISSION

To deliver a complete ecosystem of solutions and services through our innovation in smart technologies. Our mission is to provide our users with the very best in cooling & heating comfort, air quality and efficiencies to create the perfect environment what ever the scenario.

CONTENTS

01 INTRODUCTION & FEATURES /01

GLOBAL POSITION	/03
GLOBAL NETWORK	/04
HVAC SOLUTIONS IN EUROPE	/05
HVAC EUROPEAN TRAINING HUBS	/06
CONNECTED ECOSYSTEM	/07
RENEWABLE ENERGY	/08
FEATURES	/09

02 ELECTRIC WATER HEATER /14

TF7W	/16
FE3W / FE3	/17
FE1W / FE1	/18
VH3W/VH3	/19
RM1	/20
A3	/21
SQM1/SQM2	/22
LM1	/23

GLOBAL POSITION



**WORLD'S NO.1
MAJOR APPLIANCES BRAND**

Haier has been accredited with being global No.1 in major household appliances by retail sales from 2008-2024, according to data from Euromonitor.



**WORLD'S NO.1
SMART AC BRAND**

Haier is the world's No.1 connected air conditioner brand, in retail sales 2024, according to data from Euromonitor.



TOP 100 MOST VALUABLE BRANDS

Haier is the world's only IoT Ecosystem Brand that has been ranked in the Kantar BrandZ Top 100 Most Valuable Global Brands for six consecutive years.



**TOP 100
GLOBAL CHALLENGERS**

With the global landing of the Smart Home ecosystem brand, Haier Smart Home was once again listed on the Fortune Global 500.



"ESG" INTERNATIONAL AWARDS

Haier has received numerous recognitions for its ESG efforts, including the Sustainable Markets Initiative's 2023 Terra Carta Seal.



**FORTUNE'S MOST
ADMIRE COMPANIES**

Haier has been named one of the World's Most Admired Companies by Fortune's, making the sixth consecutive year the Company is on this prestigious list.



GLOBAL NETWORK

Haier currently has 10+ R&D centres, 29 industrial parks, 122 marketing centres and 108 manufacturing centres around the world, reaching out to more than 200 countries and regions and serving 1 billion user households.

Haier has 7 major home appliance brands worldwide: Haier, Casarte, Leader, AQUA, Fisher & Paykel, GE Appliances and Candy.

Each of these brands offers the best user experience to various consumer groups in many regions and countries around the world.



10+N R&D Centers	126 Marketing Centers	35 Industrial Parks	138 Factories	200+ Countries or Regions
----------------------------	---------------------------------	-------------------------------	-------------------------	-------------------------------------

HVAC SOLUTIONS IN EUROPE

Haier's European HVAC operations has been active for over 30 years where we are fully supported by some of the most talented and dedicated partners and teams across Europe including, Italy, Spain, Portugal, UK, France, Greece, Central Europe and Germany.

These markets carry a wide range of products which includes, Residential & Light Commercial solutions as well as Large Commercial and Heating Solutions, giving us a truly diverse offering to suit various applications from residential to larger Hotels and Retail. Our total production capacity is over 27 million sets per year, supported by 16 Air Conditioning factories with 8 of them being in overseas markets.

This outstanding capacity enables us to continually strive to lead the market in delivering Smart and Healthy solutions across Europe.

Haier HVAC European operations are anchored by two key hubs: Haier Iberia in Barcelona, Spain, serving Spain and other European countries and Haier AC Trading Italy, situated in Revine Lago, which caters to both the Italian and broader European markets.

Recently, the addition of Haier HVAC UK has further strengthened our presence in Europe, contributing to our ongoing growth in the region.

HVAC EUROPEAN TRAINING HUB

Since 2024, our Training Hub in Barcelona has welcomed over 3000 visitors, including installers, designers and distributors, to strengthen their knowledge of Haier's solutions.

The hub has been specifically designed to have a dedicated room for each portfolio: residential, heating, commercial and from 2024 a brand-new floor has welcomed a training room for new energy solutions. In addition, the new 3rd floor gives the opportunity to both internal and external guests to host meetings and workshops, thanks to an additional meeting room and co-working spaces accessible at all times.



HVAC EUROPEAN TRAINING HUBS

At Haier we are continually investing in opening facilities for our HVAC professionals to train and experience the Haier portfolio. We have many training centres across Europe supported by our partners. To join our training facility in Venice, in 2022 we celebrated the opening of our new HVAC European training centre in Barcelona. The new training Hub can facilitate a range of training programmes which are tailored to the needs of our professional HVAC network. The Hub has welcomed over 3000+ visitors who have all be able to get close to the brand and the complete ecosystem of solutions we have on offer.

The facilities are fully operational with 3 dedicated rooms, which includes products from our portfolio from Residential, Heating and Commercial solutions, giving visitors a truly hands on experience.

We look forward to welcoming our Distributors, Installers and Designers to come and experience Haier's HVAC Solutions first-hand.

Follow us on LinkedIn to keep up to date about upcoming events and products



CONNECTED ECOSYSTEM



A2W HEAT PUMP



ENERGY STORAGE



HP WATER HEATER



A2A HEAT PUMP



Haier solutions for renewable energy production and management

Haier has been investing for years in an integrated ecosystem that combines smart applications, renewable energy, and advanced technologies to improve quality of life and reduce environmental impact. The goal is ambitious: to contribute to the realisation of buildings with zero impact by promoting energy efficiency, reduction of CO₂ emissions, and adoption of natural refrigerants and advanced green technologies to fight global warming. Haier commitment to a more sustainable world has been increasingly more evident thanks to the introduction of Haier Energy, the brand-new Haier division dedicated to the manufacturing and distribution of photovoltaic, energy storage, power

conversion system and electric mobility across the European market through specialized distributors and wholesalers. The benefits of utilizing a comprehensive energy management system that encompasses photovoltaic panels, inverters, batteries, heat pump water heaters and ATW systems for domestic hot water, and heat pump air conditioners are significant. This integrated approach allows for seamless control and monitoring of all components through a single application, hOn. By consolidating these various technologies into one cohesive system, users can optimize energy consumption, enhance efficiency, and reduce

operational costs. Furthermore, the centralized management provided by the hOn app facilitates real-time data analysis and performance tracking, empowering users to make informed decisions regarding their energy usage while contributing to a more sustainable future.



For more scan here



Haier HVAC Solutions boasts a comprehensive portfolio spanning three key sectors: Air Conditioning, Heating and Green Energy. Throughout this portfolio Haier HVAC covers both domestic and commercial solutions but what makes Haier truly unique, is the ability to connect and integrate its range of products to create a one brand solution. Having the ability to do this simplifies all aspects of the supply chain from pre-sales through to after sales support.

The hOn application by Haier can be used to control and manage all Haier products. This gives users complete control over

how they use their energy. The hOn app includes key features such as scheduling the units working time as well as monitoring the energy usage to ensure the system is working to its optimum level.

Haier's one brand solution reinvents the way that domestic and commercial properties consume energy, putting complete control in the hands of the user to ensure all their Haier products are operating in a way that suits the user's lifestyle and environment.

ELECTRIC WATER HEATER

These compact and versatile solutions are perfect for everyday hot water needs. With compact designs for easy installation, this range of equipment covers both instant and storage electric water heaters – up to energy class B. From under-sink installations starting with our 10L solution to over 250L devices that can fit in a cupboard, this wide range of Electric Water Heaters is the perfect answer to your water heating needs.

SHOCK PROOF

Haier water heaters comes with "Shock proof" technology.

The shock proof technology plays as a resistor between the water heater and the user, which reduces the intensity of the current passed, thereby ensuring users' safety.

Patented shock proof technology adopted by IEC standard.

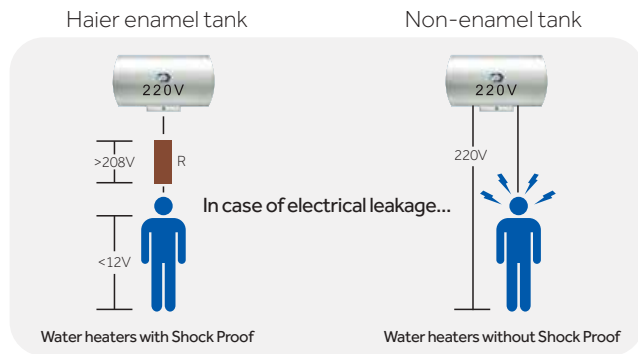

SUPER ENAMEL TANK



TITANIUM COATING TANK REINFORCES PREMIUM QUALITY

Haier Titanium Coating Tank boasts ultra-strong anti-corrosion performance, better durability and premium quality.

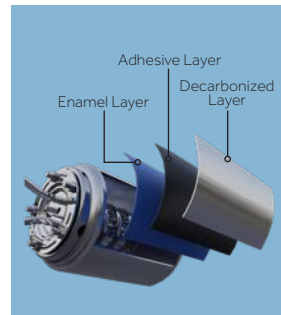

SUPER ENAMEL TANK WITH THREE LAYERS

Patented super enamel tank has an enamel layer, adhesive layer and decarbonized layer, which have better performance on anti-dissolve, anti-explosion and anti-corrosion.

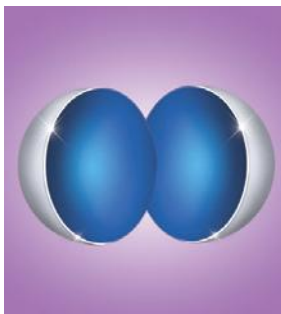

ANTI-CORROSION AND ANTI-SCALING ENAMEL POWDER DOUBLES THE DURABILITY

Enamel dedicated superfine powder increases the anti-corrosion and anti-scaling effects.

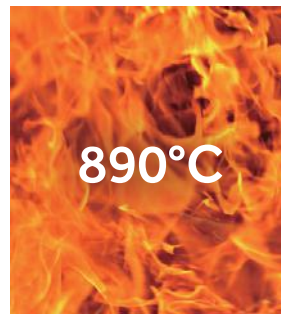

890°C DOUBLES THE PERFORMANCE

The tank is sintered at a high temperature of 890°C by using the world-leading fully-automated robotic laser tracking welding technology; the materials are interpenetrated and bonded to avoid shedding.

TITANIUM HEATING ELEMENT



The titanium heating element is made of 99.6% pure titanium material. Its outstanding corrosion performance means it can resist corrosion throughout its entire lifespan. This completely eliminates the concerns of reduced heating efficiency and electric leakage due to heating element corrosion.

COMPARISON TEST*



*Test condition: In 3% FeCl₃ liquid
*Conventional heating element is stainless steel 316L

ENAMEL HEATING ELEMENT



HIGH DURABILITY

Corrosion-resistant and high-performance, consistent heating rate keeping water clean and healthy.

MO HEATING ELEMENT

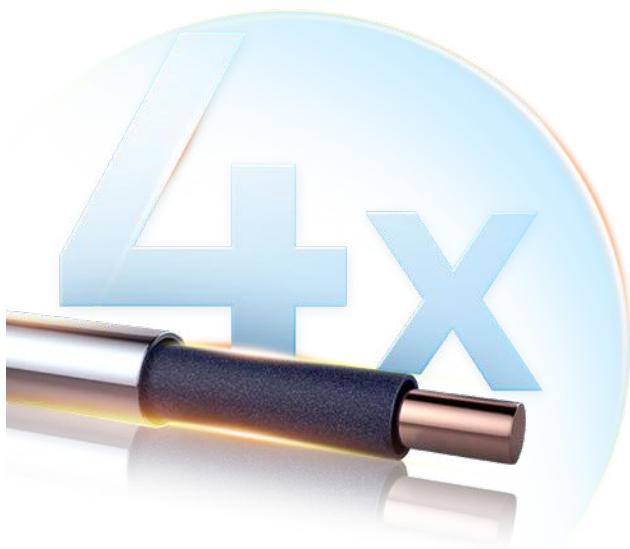

HIGH ANTI-CORROSION MO ALLOY COATING

A rare metal element, Mo, is added to fully improve the corrosion resistance, 4 times that of the common heating element, with effective anti-corrosion and anti-scaling performance alongside efficient and durable functions.



Regular Heating Element



310s+Mo Heating Element

AI ANODE ANTICORROSION SYSTEM



AI ANODE LIFETIME ANTICORROSION, GUARANTEED TO LAST WITHOUT NEEDING REPLACEMENT

Featuring leading AI Anode Anticorrosion System (Dualshield including a Iridium-lined NeuroTitan™ Active Electric Anode and a Resistive Magnesium Rod Sacrificial Anode), this water heater eliminates the need for magnesium rod replacements while ensuring lifelong tank protection. Its eco-friendly technology adapts to different water qualities, providing continuous, clean, and healthy hot water, while promoting both health and environmental sustainability.



Healthguard:
clean water without rust



Smart dual anode
constant care



Lifetime anticorrosion
without leakage



Sustainable Eco-friendly



Lifetime last
without replacement



Adapt to different
water qualities

HAIER ULTRA-THICK MAGNESIUM ROD

Reduce the consumption rate, providing longer protection for the heating element and inner tank.

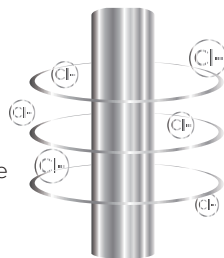

HAIER RESISTIVE MAGNESIUM ROD

The external resistor design protects it from water seepage and high temperatures, and only the magnesium rod needs to be replaced.



VS

COMPETITORS

The magnesium rod is not thick enough. It has a shorter service life and requires frequent replacement.



COMPETITORS

Internal resistors are easily damaged from water seepage and high temperatures, and both the resistor and magnesium rod need to be replaced.

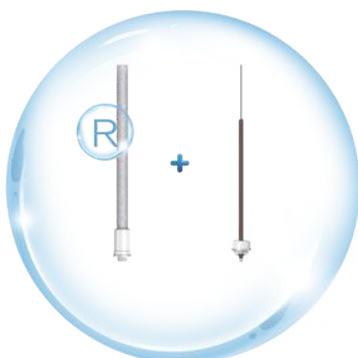

AI ANODE ANTICORROSION SYSTEM

- The electronic anode, with smart programs, monitors water and hydrogen. It adjusts the charge for tank balance and safety. Made of pure titanium, corrosion-resistant, iridium-coated with 30 year warranty.

A large resistor at the magnesium rod base enables the NeuroTitan™ anode to work

- independently for green corrosion protection. In case of power failure, the resistor fails and the magnesium rod acts as a secondary anti-corrosion measure.

U-TURN FLOW TECHNOLOGY

ENJOY A LARGE AMOUNT OF RUNNING WATER WITHOUT RESIDUAL HEAT

With the pipe-in-pipe principle, the cold water is firstly injected via inner side pipelines in an enclosed space and then outputted by 360°, evenly passing through 116 small holes via outer side pipelines. The cold water is immediately heated after entering into the tank to reduce the impact of cold water against the hot water at the top of the tank.

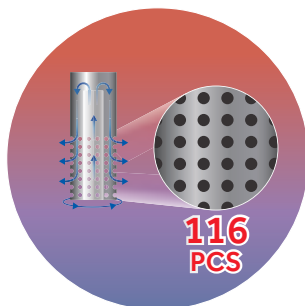

360°
Water Flowing

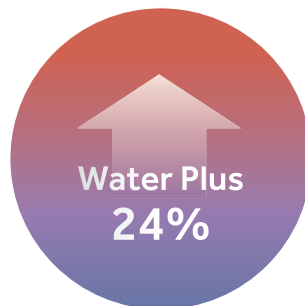

Uniformly mixed cold and hot water increases the water output, raises the output rate by 24%, and brings a more pleasant bathing experience with a large amount of water.

KEEP WATER FRESHER AND HEALTHIER WITHOUT STAGNANT WATER DEPOSITION

Different from common water heaters, the unique U-type water inlet pattern avoids the stagnant water caused by the non-flowing water at the bottom of the tank. Our units prevent stagnant water deposition, activate water circulation to keep the water fresh.

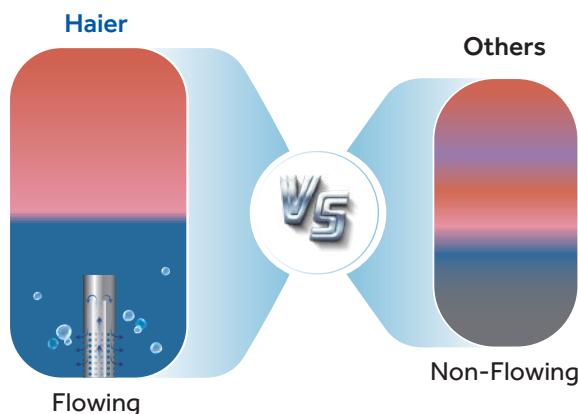

UPGRADED PUF TECHNOLOGY

UNIFORM AND DENSE HEAT INSULATION LAYER, 360° ALL-ROUND HEAT PRESERVATION

Based on the innovative S.C. nanometer super-microporous integral foam technology, the eco-friendly Polyurethane Foam (PUF) heat insulation layer is uniform and dense, achieving all-round heat preservation; the superior heat insulation effect reduces heat loss, heats a large amount of water, and gives you energy-saving hot water.

INNOVATIVE TECHNOLOGY, MORE STABLE PERFORMANCE

The injection of inert gases creates a more stable foaming status and better heat insulation performance.

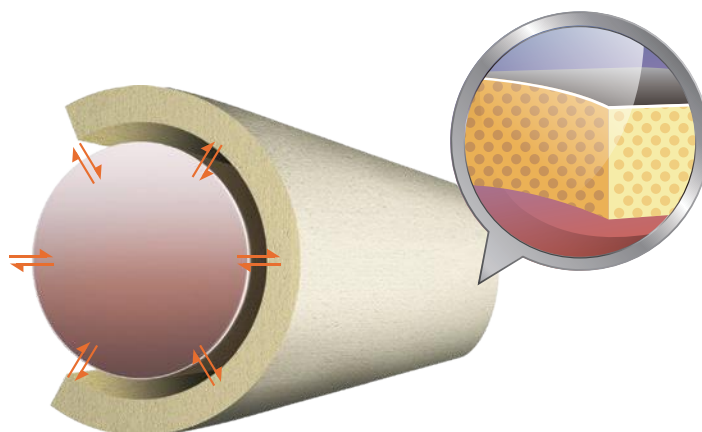

TTS TECHNOLOGY



OVERHEAT PROTECTION

With the liquid expansion thermostat, when the heating pipe continues to heat the water to or above 97°C, the thermostat will automatically power off to protect the machine and extend the service life.



PRECISE TEMPERATURE CONTROL

The inner tank blind hole makes the temperature measurement more precise; once the water is heated to the preset temperature, the heat process is immediately stopped, reacting quicker and saving more energy and electricity.

TTS TECHNOLOGY Thermal cut-out + Thermostat

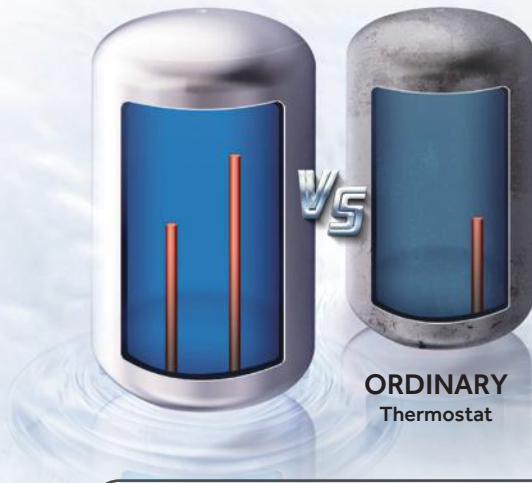

ORDINARY
Thermostat

Liquid expansion thermostat

Monitor the temperature by physical principles without being affected by electric circuits; go deep into the inner tank to measure the temperature in a quicker, safer and more reliable way.



Electronic wall mounted thermostat

Slow reaction and low reliability of electronic components.



80°C BACTERIA PROOF SYSTEM



As we know, the inner tank of the water heater is the part where bacteria are most likely to grow, because of the mixture of hot and cold water, but Haier water heater's unique BPS technology can solve this problem.



80°C BPS HIGH-TEMPERATURE STERILIZATION LEADING THE INDUSTRY

Compared with common products in the industry that can only heat the water to 65°C, Haier self-developed liner provides a good pressure bearing capacity, A sterilization temperature of up to 80°C and better sterilization effects.



CLEAN WATER FOR EXTRA SAFETY

With a high sterilizing rate of 99.9%, the more efficient anti-bacteria protection system effectively cleans the water and cares for your skin.

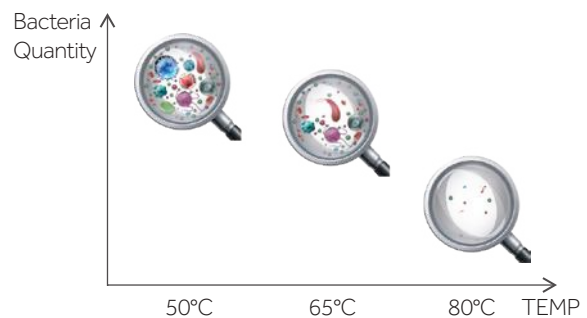









At 80°C, most bacterial proteins, such as listeria, are broken down by the heat.

EWH MODEL LINEUP

SERIES	10	15	30	50	80	100	150	200	300
 <p>TF7W</p>				•	•	•			
 <p>FE3 / FE3W</p>				•	•	•			
 <p>FE1 / FE1W</p>				•	•	•			
 <p>VH3/VH3W</p>			•	•	•	•			
 <p>A3</p>			•	•	•	•			
 <p>RM1</p>					•	•	•		
 <p>LM1</p>								•	•
 <p>SQM</p>	•	•	•						

EWH FEATURES

SERIES	Type	Energy class	Wifi	Installation type	Control way	Heating element	Corrosion protection	Universal Features
 TF7W	Flat	B	Yes	Horizontal + Vertical	Electronical	Titanium	Magnesium Anode	Bacteria Proof System + Shock Proof + Over pressure Protection + Heat Loss prevention + U-Turn Technology
 FE3W / FE3	Flat	B	Yes	Horizontal + Vertical	Electronical	Enamel Heating Element	Electronic Anode + Magnesium Anode	
 FE1W / FE1	Flat	B	Yes	Horizontal + Vertical	Electronical	310S+MO	Magnesium Anode	
 VH3/VH3W	Round	B	Yes	Horizontal + Vertical	Electronical	310S+MO	Magnesium Anode	
 A3	Round	C	No	Vertical	Mechanical	310S+MO	Magnesium Anode	
 RM1	Round	C	No	Horizontal + Vertical	Mechanical	310S+MO	Magnesium Anode	
 LM1	Floor Standing	C	No	Floor Standing	Mechanical	310S+MO	Magnesium Anode	
 SQM	Mini	A	No	Vertical	Mechanical	310S+MO	Aluminum Rod	

TF7W - ES50/80/100V

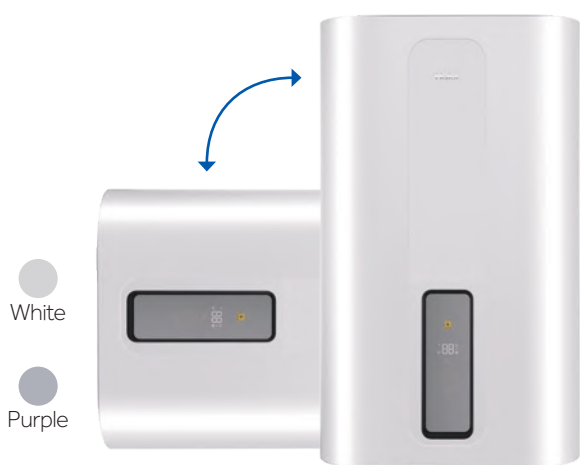

Shock Proof
Ensuring safety for all users.



Double Tank
With its durable enamel coating and double tank design, the product ensures healthy and long lasting water.



Titanium Heating Element
Titanium heating element is non-corrodible.



Eco-smart



Bacteria Proof System



Wi-Fi



Super Volume



Multi position (V/H)

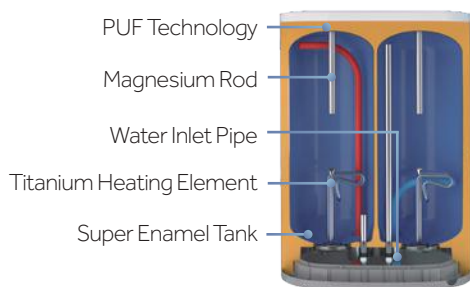

Control Panel

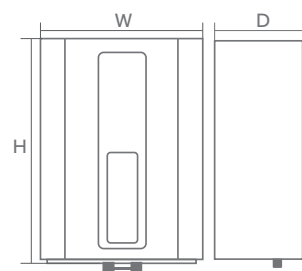

Model	ES50V-TF7W	ES80V-TF7W	ES100V-TF7W
Installation type	Vertical + Horizontal	Vertical + Horizontal	Vertical + Horizontal
Control method	Electronic	Electronic	Electronic
Capacity (L)*	50	80	100
Material of inner tank	Enamel stainless steel	Enamel stainless steel	Enamel stainless steel
Material of outer body	PCM	PCM	PCM
Material of heating element	Ti	Ti	Ti
Rated voltage (V)/frequency (Hz)	230/50	230/50	230/50
Rated power (W)	3000	3000	3000
Rated temperature (°C)	75	75	75
Rated pressure (bar)	8	8	8
Water-proof grade	IPX4	IPX4	IPX4
Function	WIFI, BPS, ECO, MAX	WIFI, BPS, ECO, MAX	WIFI, BPS, ECO, MAX
Product dimensions W/D/H (mm)	530*320*745	530*320*1070	530*320*1312
Packing dimensions W/D/H (mm)	613*403*860	604*406*1185	610*410*1430
Net weight (kg)	25	33.5	41
Gross weight (kg)	28.6	38	46
Energy class	B	B	B
Qty.40HQ	318	212	185

* The size indication refers to capacity; the actual volume is specified in the technical documentation.

FE3W / FE3 - ES50/80/100V



Shock Proof

Ensuring safety for all users



DualEnamel™ Heating Tech

Super enamel tank and enamel heating element, corrosion-resistant and high-performance. Consistent heating performance keeping water clean and healthy.



3kW Twin Power

Providing a continuous supply of hot water to meet the high demands of households.



hOn Wi-Fi



ErP Class B



Multiposition (V/H)



Customized Bathing



Bacteria Proof System



AI Anode Anticorrosion System

Lifetime anticorrosion, guaranteed to last without replacement, providing continuous, clean, and healthy hot water.

MAX Indicator
ECO Indicator
BPS Indicator



Control Panel

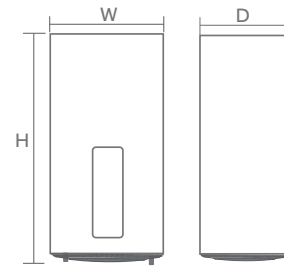

Model	ES50V-FE3	ES80V-FE3	ES100V-FE3
Installation type	Vertical + Horizontal	Vertical + Horizontal	Vertical + Horizontal
Control method	Electronic	Electronic	Electronic
Capacity (L)*	50	80	100
Material of inner tank	Enamel	Enamel	Enamelt
Material of outer body	PCM	PCM	PCM
Material of heating element	Enamel	Enamel	Enamel
Rated voltage (V)/frequency (Hz)	220-240/50	220-240/50	220-240/50
Rated power (W)	3000	3000	3000
Rated temperature (°C)	75	75	75
Rated pressure (bar)	8	8	8
Water-proof grade	IPX4	IPX4	IPX4
Function	ECO, BPS, MAX Electronic Anode	ECO, BPS, MAX Electronic Anode	ECO, BPS, MAX Electronic Anode
Product dimensions W/D/H (mm)	530*320*745	530*320*1070	530*320*1312
Packing dimensions W/D/H (mm)	610*410*860	610*410*1178	610*410*1383
Net weight (kg)	25	34	40
Gross weight (kg)	28	38	44
Energy class	B	B	B
Qty.40HQ	318	212	185

* The size indication refers to capacity; the actual volume is specified in the technical documentation.

FE1W / FE1 - ES50/80/100V



Shock Proof

Ensuring safety for all users



Super Enamel Tank

Ultra-strong durability and anti-corrosion performance.



310S+Mo Heating Element

High anti-corrosion Mo alloy coating, 4 times that of the common heating element.



Bacteria Proof System



Double Tank



Multiposition (V/H)



hOn Wi-Fi



Butt Welding Technology

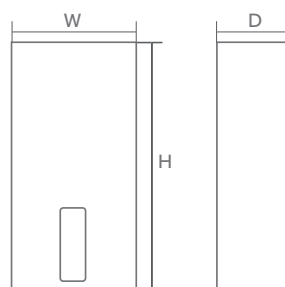

Model	ES50V-FE1	ES80V-FE1	ES100V-FE1
Installation type	Vertical + Horizontal	Vertical + Horizontal	Vertical + Horizontal
Control method	Electronic	Electronic	Electronic
Capacity (L)*	50	80	100
Material of inner tank	Super enamel tank	Super enamel tank	Super enamel tank
Material of outer body	PCM	PCM	PCM
Material of heating element	310S+Mo	310S+Mo	310S+Mo
Rated voltage (V)/frequency (Hz)	220-240/50	220-240/50	220-240/50
Rated power (W)	2000	2000	2000
Rated temperature (°C)	80	80	80
Rated pressure (bar)	8	8	8
Water-proof grade	IPX4	IPX4	IPX4
Function	WiFi, BPS	WiFi, BPS	WiFi, BPS
Product dimensions W/D/H (mm)	530*323*755	530*323*1068	530*323*1278
Packing dimensions W/D/H (mm)	615*415*860	615*415*1178	615*415*1383
Net weight (kg)	25	34	40
Gross weight (kg)	28	38	44
Energy class	B	B	B
Qty.40HQ	318	212	185

* The size indication refers to capacity; the actual volume is specified in the technical documentation.

VH3W / VH3 - ES30/50/80/100V



White

Golden

*Available for VH3



Shock Proof

Ensuring safety for all users.



Super Enamel Tank

Ultra-strong durability and anti-corrosion performance.



310S+Mo Heating Element

High anti-corrosion Mo alloy coating, 4 times that of the common heating element.



Ergonomic Control Panel



ErP Class B



U-turn Flow Technology



hOn Wi-Fi

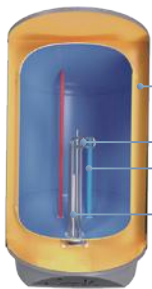

PUF Technology

310S+Mo Heating Element

U-turn Flow Technology

Magnesium Rod



Smart Wi-Fi Control

*Available for VH3W

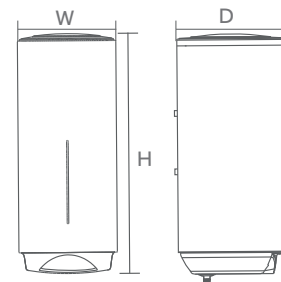

Model	ES30V-VH3W/VH3	ES50V-VH3W/VH3	ES80V-VH3W/VH3	ES100V-VH3W/VH3
Installation type	Vertical + Horizontal	Vertical + Horizontal	Vertical + Horizontal	Vertical + Horizontal
Control method	Electronic	Electronic	Electronic	Electronic
Capacity (L)*	30	50	80	100
Material of inner tank	Enamel	Enamel	Enamel	Enamel
Material of outer body	SPCC	SPCC	SPCC	SPCC
Material of heating element	310S+Mo	310S+Mo	310S+Mo	310S+Mo
Rated voltage (V)/frequency (Hz)	230/50	230/50	230/50	230/50
Rated power (W)	1500	1500	1500	1500
Rated temperature (°C)	75	75	75	75
Rated pressure (bar)	8	8	8	8
Water-proof grade	IPX4	IPX4	IPX4	IPX4
Function	BPS, ECO (WIFI for VH3W)	BPS, ECO (WIFI for VH3W)	BPS, ECO (WIFI for VH3W)	BPS, ECO (WIFI for VH3W)
Product dimensions W/D/H (mm)	421*410*530	421*410*686	421*410*995	421*410*1230
Packing dimensions W/D/H (mm)	496*486*580	496*486*723	496*486*1032	496*486*1280
Net weight (kg)	13	18	26	30
Gross weight (kg)	15	21	29	34
Energy class	A	B	B	B
Qty.40HQ	384	315	210	192

* The size indication refers to capacity; the actual volume is specified in the technical documentation.

RM1 - ES80/100V/150V



Shock Proof

Ensuring safety for all users.



Super Enamel Tank

Ultra-strong durability and anti-corrosion performance.



310S+Mo Heating Element

High anti-corrosion Mo alloy coating, 4 times that of the common heating element.



Ergonomic Dial Control

Ergonomically designed for effortless operation.



MAX Button

Control Panel

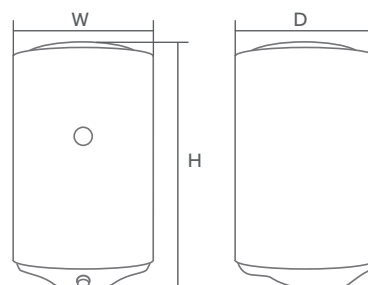

Q1 2026

Model	ES80V-RM1	ES100V-RM1	ES150V-RM1
Installation type	Vertical + Horizontal	Vertical + Horizontal	Vertical + Horizontal
Control method	Mechanical	Mechanical	Mechanical
Capacity (L)*	80	100	150
Material of inner tank	Enamel	Enamel	Enamel
Material of outer body	Painted SPCC	Painted SPCC	Painted SPCC
Material of heating element	310S+Mo	310S+Mo	310S+Mo
Rated voltage (V)/frequency (Hz)	220-240/50	220-240/50	220-240/50
Rated power (W)	1500	1500	2000
Rated temperature (°C)	75	75	75
Rated pressure (bar)	7	7	7
Water-proof grade	IPX4	IPX4	IPX4
Product dimensions W/D/H (mm)	452*468*768	452*468*913	452*468*1260
Packing dimensions W/D/H (mm)	530*530*828	530*530*973	530*530*1363
Net weight (kg)	23	26	35
Gross weight (kg)	26	31	46
Energy class	C	C	C
Qty.40HQ	314	266	TBC

* The size indication refers to capacity; the actual volume is specified in the technical documentation.

A3 - ES30/50/80/100V



Shock Proof

Ensuring safety for all users.



Super Enamel Tank

Ultra-strong durability and anti-corrosion performance.



310S+Mo Heating Element

High anti-corrosion Mo alloy coating, 4 times that of the common heating element.

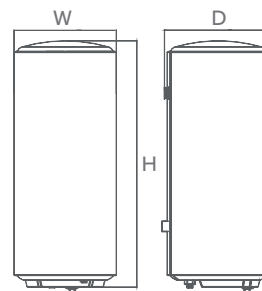

Optional colors for end cover and thermometer configurations.

Model	ES30V-A Series	ES50V-A Series	ES80V-A Series	ES100V-A Series
Installation type	Vertical	Vertical	Vertical	Vertical
Control method	Mechanical	Mechanical	Mechanical	Mechanical
Capacity (L)*	30	50	80	100
Material of inner tank	Enamel stainless steel	Enamel stainless steel	Enamel stainless steel	Enamel stainless steel
Material of outer body	SPCC	SPCC	SPCC	SPCC
Material of heating element	310S+Mo	310S+Mo	310S+Mo	310S+Mo
Rated voltage (V)/frequency (Hz)	220-240/50	220-240/50	220-240/50	220-240/50
Rated power (W)	1500	1500	1500	1500
Rated temperature (°C)	75	75	75	75
Rated pressure (bar)	8	8	8	8
Water-proof grade	IPX4	IPX4	IPX4	IPX4
Product dimensions W/D/H (mm)	390*400*447	390*400*650	390*400*930	390*400*1160
Packing dimensions W/D/H (mm)	446*446*505	452*452*686	452*452*986	452*452*1210
Net weight (kg)	11	15	23	28
Gross weight (kg)	13	17	25	31
Energy class	B	C	C	C
Qty.40HQ	645	475	319	260

* The size indication refers to capacity; the actual volume is specified in the technical documentation.

SQM1/SQM2 - ES10/15/30V



Shock Proof

Ensuring safety for all users.



Single-weld Line Tank

Durable and anti corrosive technology.



310S+Mo Heating Element

High anti-corrosion Mo alloy coating, 4 times that of the common heating element.



High Efficiency

Max energy efficiency with ErP class A.



Titanium Coating Tank

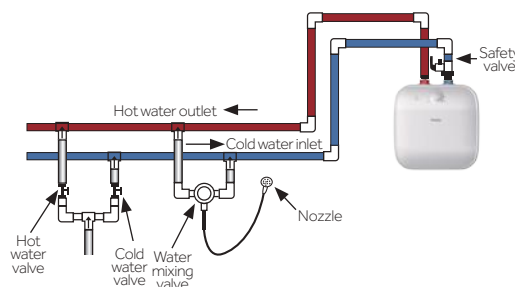
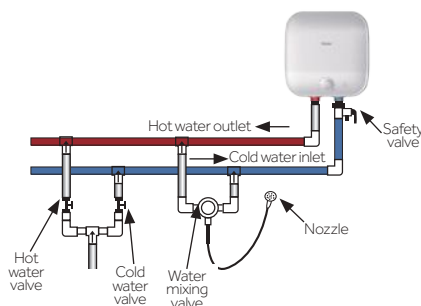

Model	ES10V-SQM1	ES10V-SQM2	ES15V-SQM1	ES15V-SQM2	ES30V-SQM1	ES30V-SQM2
Load profile	Vertical	XXS	XXS	XXS	S	S
Energy class	A	A	A	A	C	C
Energy efficiency (%)	36	35	35	36	33.72	32.3
Annual electricity consumption (kWh)	508	527	520	507	547	571
Sound power level indoors (dB)	10.8	8.32	/	13.14	43.8	40
V40 (L)	10.8	8.32	/	15	15	15
Rated voltage/frequency (V/Hz)	220-240/50	220-240/50	220-240/50	220-240/50	220-240/50	220-240/50
Rated power (W)	1500	1500	1500	1500	1500	1500
Rated temperature (°C)	75	75	75	75	75	75
Water-proof grade	IPX4	IPX4	IPX4	IPX4	IPX4	IPX4
Rated pressure (bar)	7.5	7.5	7.5	7.5	8.5	8.5
Packing dimensions W/D/H (mm)	360*270*360	360*270*360	360*340*360	360*340*360	445*380*445	445*380*445
Net weight (kg)	7	7	8.5	8.5	14	14
Gross weight (kg)	8.5	8.5	10	10	16	16
Qty.40HQ	1156	1156	870	870	600	600

* The size indication refers to capacity; the actual volume is specified in the technical documentation.

LM1 - ES200/300VT



Super Enamel Tank

Ultra-strong durability and anti-corrosion performance.



310S+Mo Heating Element

High anti-corrosion Mo alloy coating, 4 times that of the common heating element.



PUF Technology

Uniform and dense heat insulation layer, 360° all-round heat preservation.

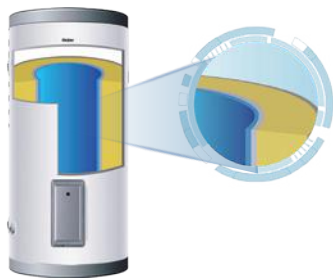

PUF Technology

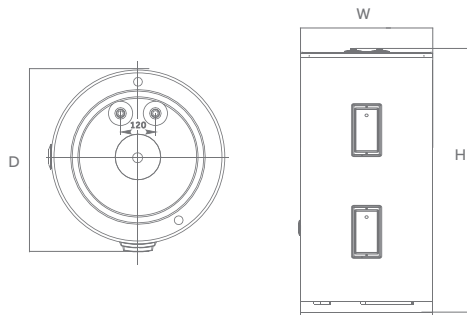

Model	ES200V-LM1	ES300V-LM1
Installation type	Floor mounted	Floor mounted
Control method	Mechanical	Mechanical
Capacity (L)	188	277
Material of heating element	310S+Mo	310S+Mo
Rated voltage (V)/frequency (Hz)	220-240/50	220-240/50
Rated power (W)	2150	2700
Rated temperature (°C)	60	60
Rated pressure (bar)	8.5	8.5
Water-proof grade	IPX4	IPX4
Product dimensions W/D/H (mm)	629*601*1220	629*601*1650
Packing dimensions W/D/H (mm)	738*710*1395	738*710*1840
Energy class	C	C
Net weight (kg)	61	82
Gross weight (kg)	70	93
Qty.40HQ	72	67

Haier

Heating

The new name in
heating

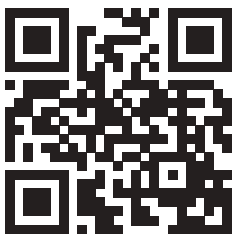
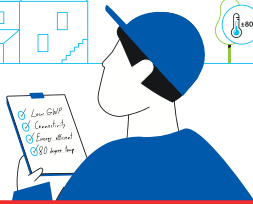

Haier HVAC
haierhvac.eu

