

# Haier

More Creation, More Possibilities

# Haier

Heating

## Heatpump Water Heaters

—  
Brochure 2026





Haier



# Haier

**More Creation, More Possibilities**

Professional, Smart & Healthy Air Solutions Provider

---

## **OUR VISION**

To be a globally recognised expert in smart and healthy Air Solutions.

## **OUR MISSION**

To deliver a complete ecosystem of solutions and services through our innovation in smart technologies. Our mission is to provide our users with the very best in cooling & heating comfort, air quality and efficiencies to create the perfect environment what ever the scenario.

# CONTENTS

---

## **01** INTRODUCTION & FEATURES /01

GLOBAL POSITION .....	/03
GLOBAL NETWORK .....	/04
HVAC SOLUTIONS IN EUROPE .....	/05
HVAC EUROPEAN TRAINING HUBS .....	/06
CONNECTED ECOSYSTEM .....	/07
RENEWABLE ENERGY .....	/08
FEATURES .....	/09

## **02** HEAT PUMP WATER HEATER /19

M8 R290 .....	/19
M7 R290 .....	/21

## **03** INSTALLATION GUIDE /23

CONNECTIONS .....	/24
-------------------	-----

# GLOBAL POSITION



**WORLD'S NO.1  
MAJOR APPLIANCES BRAND**

Haier has been accredited with being global No.1 in major household appliances by retail sales from 2008-2024, according to data from Euromonitor.



**WORLD'S NO.1  
SMART AC BRAND**

Haier is the world's No.1 connected air conditioner brand, in retail sales 2024, according to data from Euromonitor.



**TOP 100 MOST VALUABLE BRANDS**

Haier is the world's only IoT Ecosystem Brand that has been ranked in the Kantar BrandZ Top 100 Most Valuable Global Brands for six consecutive years.



**TOP 100  
GLOBAL CHALLENGERS**

With the global landing of the Smart Home ecosystem brand, Haier Smart Home was once again listed on the Fortune Global 500.



**"ESG" INTERNATIONAL AWARDS**

Haier has received numerous recognitions for its ESG efforts, including the Sustainable Markets Initiative's 2023 Terra Carta Seal.



**FORTUNE'S MOST  
ADMIRE COMPANIES**

Haier has been named one of the World's Most Admired Companies by Fortune's, making the sixth consecutive year the Company is on this prestigious list.



# GLOBAL NETWORK

Haier currently has 10+ R&D centres, 29 industrial parks, 122 marketing centres and 108 manufacturing centres around the world, reaching out to more than 200 countries and regions and serving 1 billion user households.

Haier has 7 major home appliance brands worldwide: Haier, Casarte, Leader, AQUA, Fisher & Paykel, GE Appliances and Candy.

Each of these brands offers the best user experience to various consumer groups in many regions and countries around the world.



<b>10+N</b> R&D Centers	<b>126</b> Marketing Centers	<b>35</b> Industrial Parks	<b>138</b> Factories	<b>200+</b> Countries or Regions
----------------------------	---------------------------------	-------------------------------	-------------------------	-------------------------------------

# HVAC SOLUTIONS IN EUROPE

Haier's European HVAC operations has been active for over 30 years where we are fully supported by some of the most talented and dedicated partners and teams across Europe including, Italy, Spain, Portugal, UK, France, Greece, Central Europe and Germany.

These markets carry a wide range of products which includes, Residential & Light Commercial solutions as well as Large Commercial and Heating Solutions, giving us a truly diverse offering to suit various applications from residential to larger Hotels and Retail. Our total production capacity is over 27 million sets per year, supported by 16 Air Conditioning factories with 8 of them being in overseas markets.

This outstanding capacity enables us to continually strive to lead the market in delivering Smart and Healthy solutions across Europe.

Haier HVAC European operations are anchored by two key hubs: Haier Iberia in Barcelona, Spain, serving Spain and other European countries and Haier AC Trading Italy, situated in Revine Lago, which caters to both the Italian and broader European markets.

Recently, the addition of Haier HVAC UK has further strengthened our presence in Europe, contributing to our ongoing growth in the region.

## HVAC EUROPEAN TRAINING HUB

Since 2024, our Training Hub in Barcelona has welcomed over 3000 visitors, including installers, designers and distributors, to strengthen their knowledge of Haier's solutions.

The hub has been specifically designed to have a dedicated room for each portfolio: residential, heating, commercial and from 2024 a brand-new floor has welcomed a training room for new energy solutions. In addition, the new 3rd floor gives the opportunity to both internal and external guests to host meetings and workshops, thanks to an additional meeting room and co-working spaces accessible at all times.



# HVAC EUROPEAN TRAINING HUBS

At Haier we are continually investing in opening facilities for our HVAC professionals to train and experience the Haier portfolio. We have many training centres across Europe supported by our partners. To join our training facility in Venice, in 2022 we celebrated the opening of our new HVAC European training centre in Barcelona. The new training Hub can facilitate a range of training programmes which are tailored to the needs of our professional HVAC network. The Hub has welcomed over 3000+ visitors who have all be able to get close to the brand and the complete ecosystem of solutions we have on offer.

The facilities are fully operational with 3 dedicated rooms, which includes products from our portfolio from Residential, Heating and Commercial solutions, giving visitors a truly hands on experience.

We look forward to welcoming our Distributors, Installers and Designers to come and experience Haier's HVAC Solutions first-hand.

**Follow us on LinkedIn to keep up to date about upcoming events and products**



# CONNECTED ECOSYSTEM



**A2W HEAT PUMP**



**ENERGY STORAGE**



**HP WATER HEATER**



**A2A HEAT PUMP**



# Haier solutions for renewable energy production and management

Haier has been investing for years in an integrated ecosystem that combines smart applications, renewable energy, and advanced technologies to improve quality of life and reduce environmental impact. The goal is ambitious: to contribute to the realisation of buildings with zero impact by promoting energy efficiency, reduction of CO<sub>2</sub> emissions, and adoption of natural refrigerants and advanced green technologies to fight global warming. Haier commitment to a more sustainable world has been increasingly more evident thanks to the introduction of Haier Energy, the brand-new Haier division dedicated to the manufacturing and distribution of photovoltaic, energy storage, power

conversion system and electric mobility across the European market through specialized distributors and wholesalers. The benefits of utilizing a comprehensive energy management system that encompasses photovoltaic panels, inverters, batteries, heat pump water heaters and ATW systems for domestic hot water, and heat pump air conditioners are significant. This integrated approach allows for seamless control and monitoring of all components through a single application, hOn. By consolidating these various technologies into one cohesive system, users can optimize energy consumption, enhance efficiency, and reduce

operational costs. Furthermore, the centralized management provided by the hOn app facilitates real-time data analysis and performance tracking, empowering users to make informed decisions regarding their energy usage while contributing to a more sustainable future.



For more scan here



Haier HVAC Solutions boasts a comprehensive portfolio spanning three key sectors: Air Conditioning, Heating and Green Energy. Throughout this portfolio Haier HVAC covers both domestic and commercial solutions but what makes Haier truly unique, is the ability to connect and integrate its range of products to create a one brand solution. Having the ability to do this simplifies all aspects of the supply chain from pre-sales through to after sales support.

The hOn application by Haier can be used to control and manage all Haier products. This gives users complete control over

how they use their energy. The hOn app includes key features such as scheduling the units working time as well as monitoring the energy usage to ensure the system is working to its optimum level.

Haier's one brand solution reinvents the way that domestic and commercial properties consume energy, putting complete control in the hands of the user to ensure all their Haier products are operating in a way that suits the user's lifestyle and environment.

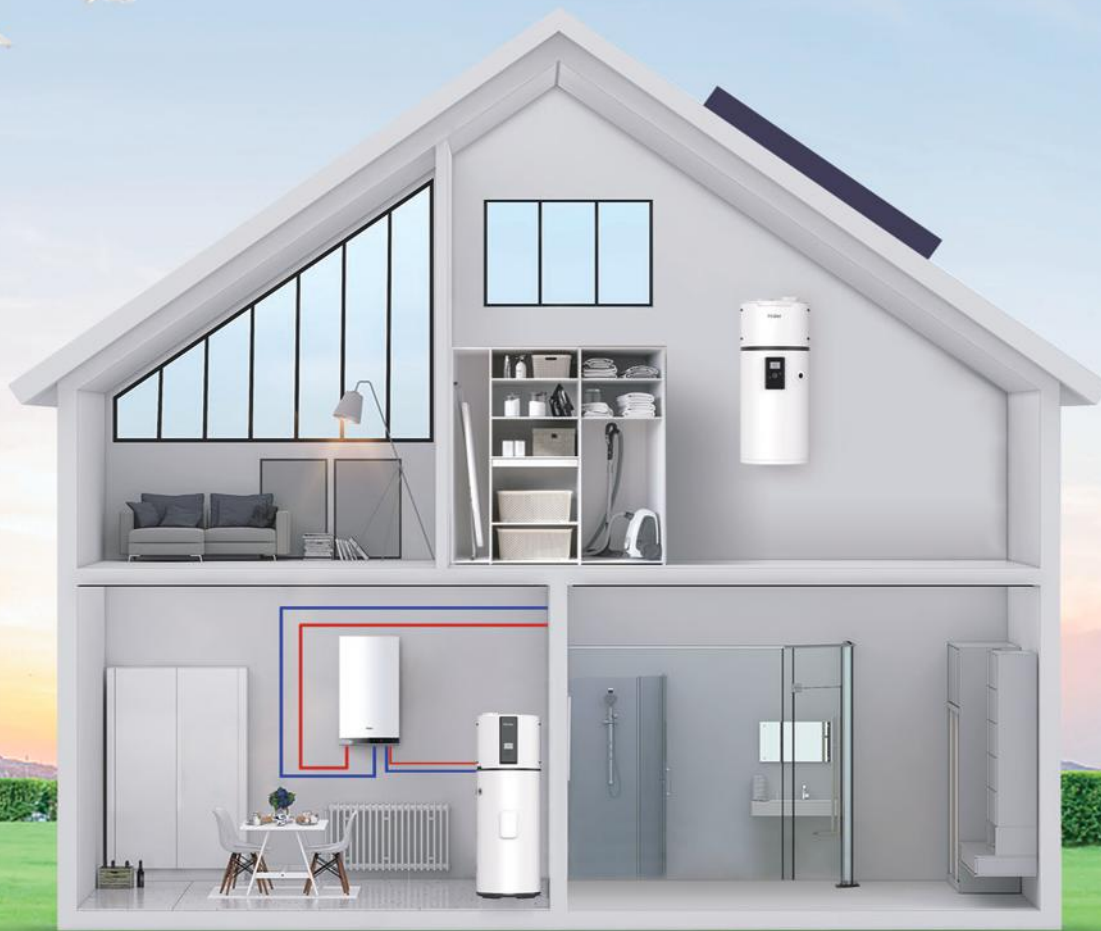

# WHAT IS A HEAT PUMP WATER HEATER?

Our range of Heat Pump Water Heaters provides a direct solution to your hot water necessities. It combines the renewable energy of a heat pump with a storage capacity of 80-250 L, allowing adaptations to a wide range of applications ranging from small homes to light commercial scenarios. This system will provide domestic hot water at a fraction of the cost of older technologies, the installation only involves water piping, therefore it is suitable for renewing previous hot water installations easily and conveniently. In 2024 we introduced the R290 Heat Pump Water Heater range which is both greener and more efficient.

# HOW IT WORKS?

To understand the concept of heat pumps, imagine a refrigerator working in reverse. While a refrigerator removes heat from an enclosed box and expels that heat to the surrounding air, a HPWH takes the heat from surrounding air and transfers it to water in an enclosed tank.

A refrigerant changes state, through compression and expansion cycles, absorbing the heat in the air at low temperature and transferring it to domestic water at a higher temperature.

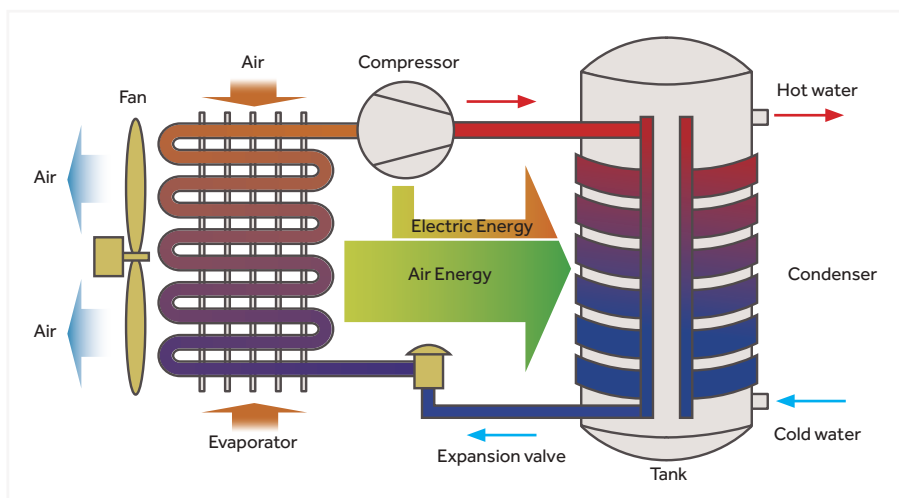

## CONDENSER DESIGN



### MICRO-CHANNEL CONDENSER

The micro-channel condenser has larger contact surface for better heat transfer performance and less refrigerant consumption.



### BOTTOM COIL

An extra coil fitted to the bottom of the tank increases the heat exchange area to deliver more hot water and contributes to better efficiency.

## CONDENSER MICRO-CHANNEL VS COIL PIPE



### Multiple channel design

Every piece of a micro-channel condenser has 18 micro-channels, which compared to the single-channel coil pipes offer much more contact surface.



### Titanium - aluminum alloy for better corrosion & heat resistances

We test the microchannel coil using salt spray for 1500 hours to prove its corrosion resistance.



### Reduces the pressure drop which improves compressor efficiency by 6%

Micro-channel: pressure drop 0.03Mpa  
Coil pipe: pressure drop 0.15Mpa

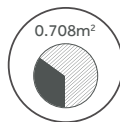

### Larger contact surface improves heat transfer efficiency by 30%

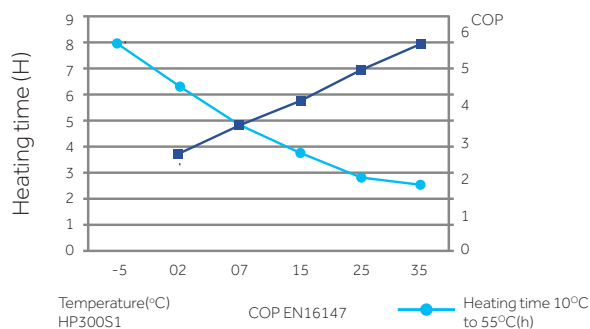
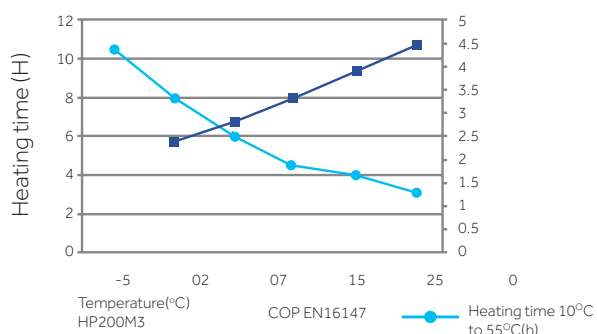

Micro-channel: contact surface 0.708m<sup>2</sup>  
Coil pipe: contact surface 0.236m<sup>2</sup>

## PERFORMANCE CURVE



The data in this catalogue is purely indicative as the data may vary. Please be advised to check the accuracy of the data with the supplier before purchasing products.

# R290 HPWH MODEL LINEUP

SERIES	MONOBLOC	
	 M8	 M7
80L	•	-
110L	•	-
150L	•	-
200L	-	•
200L With Solar	-	•
250L	-	•
250L With Solar	-	•

SERIES	MONOBLOC - FEATURES	
<b>Product Code</b>	<b>M8</b> HP80M8-9 HP110M8-9 HP150M8-9	<b>M7</b> HP200M7-F9 HP200M7C-F9 HP250M7-F9 HP250M7C-F9
<b>Description</b>	Monobloc type heat pumps are packaged equipment, which includes all hydraulic components. It consists of only one outdoor unit. The advantage of the monobloc system is easy installation and no additional refrigerant piping requirement.	
SG ready	●	●
Solar connection	-	● (200C & 250C)
Exhaust	●	●
hOn WiFi	●	●
Refrigerant	R290	R290
Max. water temperature	65°C	65°C
Energy rating	A+	A+
Mute Mode	36dB(A)	36dB(A)
COP @14°C	3,39	3,50
Micro channel condenser	●	●
Inverter	-	●
DC motor	●	●
Electr. Heater	1,200W	1,500W
Smart defrost	●	●
Tank material	Enamel	Enamel
Display	●	●
Modes	Auto, Eco, Boost, Vac	Auto, Eco, Boost, Vac
Sterilisation	75°C	75°C

# ECO R290 REFRIGERANT



## R290 Refrigerant, More Eco-friendly

In order to achieve carbon neutrality and mitigate the impact of global warming, Haier is introducing a series air source heat pump water heaters using R290 natural refrigerant. This advanced household water solution, offer sustainable, green and comfortable hot water solutions.



## Excellent Thermodynamic Performance

R290 refrigerant offers excellent thermodynamic performance, allowing for higher water temperatures to meet various application demands.

## Higher water temperatures for safe showering

For Showers



## Up to 65°C Water Temperature

The HPWH works alone to deliver water temperature as high as 65°C, and the water mixing rate at 40 °C can reach 130%\*. The equivalent to 30% capacity increase, saving power and enjoying required hot water supply.



\*Model: HP110M8-9

## Natural, Non-toxic, and Free of Ozone Depletion

R290 is a high-purity propane refrigerant with a global warming potential (GWP) of 3.



# MULTI-ENERGY CONNECTED

## Multi-energy Connected

Combine with boiler, solar thermal, PV, save energy and reduce costs.



### Solar Water Heater & Heat Pump Water Heater

Priority given to solar energy, which greatly reduces energy costs for users.

### Gas Boiler & Heat Pump Water Heater

As a complimentary energy source for heat pumps to achieve higher water temperatures.



### PV & Heat Pump Water Heater

Select PV power to save electricity cost.



# EFFICIENCY



## Micro-channel Condenser Upgraded for R290 Refrigerant

The surface contact heat exchange area is larger, and the refrigerant is fully fed and heat is exchanged in a very small flow path, which greatly improves the efficiency of heat exchange compared to traditional heat exchangers.

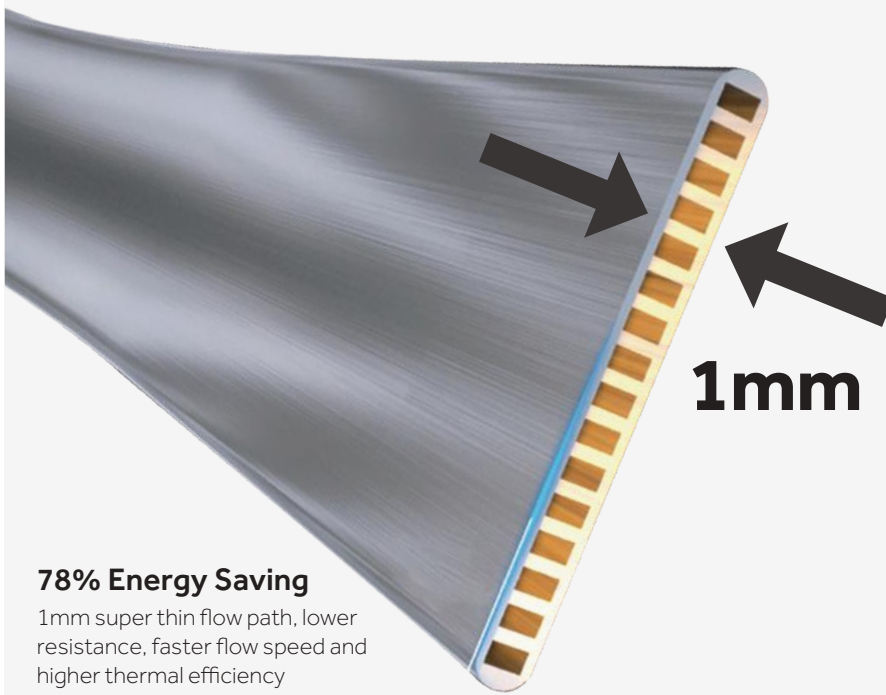

### 78% Energy Saving

1mm super thin flow path, lower resistance, faster flow speed and higher thermal efficiency



Increase heat transfer efficiency



Reduce power consumption



Improve Performance

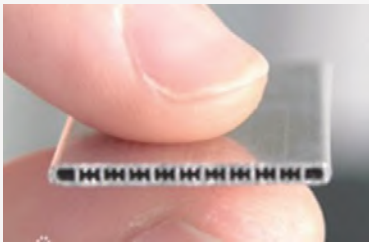

Multi-path design with multiple ultra-fine micro-channels in each path, enabling more efficient heat transfer while reducing flow resistance and lowering power consumption, resulting in a performance improvement.



The larger heat transfer surface area leads to an increase in heat transfer efficiency.



Uniform heating with temperature differences of within 4°C between the upper and lower layers, minimal stratification of hot water, outperforming copper pipe heat exchangers, and effectively reducing power consumption.



## Dual Power Heating, Enables Faster Hot Water Production

The electric heating (1200/1500W electric auxiliary) can be started at the same time to improve the heating efficiency in case of low temperature in the winter, or if there is an urgent need of a large amount of hot water, this achieves fast heating of the tank of water in a short time.



## Smart Defrost, More Efficient and Energy Saving

Haier's smart defrosting control system is equipped with a four-way valve and an electronic expansion valve with higher refrigerant flow control accuracy, the defrosting effect is more efficient, so it frosts less in low temperature conditions.



## A Quiet Home, A Comfortable Life

Haier's advanced 2.0 noise reduction system, including DC motor and patent air supply structure, guarantees whisper-quiet operation without compromising performance.

Activity	Noise Level (dB)
Aircraft takeoff	120dB
Drill	100dB
Heavy traffic	80dB
Conversation	60dB
Library	36dB*
Breath	20dB*

\*Sound pressure at 1m

# SMART & CONVENIENT



## Connect and Control from Anywhere, Anytime

Haier's R290 range of air source heat pump water heater can be operated from your mobile devices via WIFI. With the hOn app, you can easily control the heat pump anytime from anywhere.

### hOn App: Your Smart Life Companion

Your appliance can be connected to your home wireless network and operated remotely using the app.

**Getting started**

- 1** Ensure that your home WiFi network is turned on
- 2** After startup, it will enter fast pairing mode without the need for manual operation
- 3** If the connection is successful, the WiFi icon will always be on

**On your mobile device**

- 1** Download the app from [hon-smarthome.com](http://hon-smarthome.com)
- 2** Register and create an account
- 3** Add your appliance and set up the WiFi connection.



## Large Screen Display



### Auto Mode

Automatically heats water to set temperature and maintains it.



### ECO Mode

In this mode, priority of heat pump heating; User entered timer settings.



### ELEC Mode

In this mode, the backup element is used as the only heat source. This function ensures hot water supply if the heat pump is not working properly.



### BOOST Mode

Heat pump and backup element are activated at the same time.



### VAC Mode

Maintains a minimum temperature to prevent freezing.

# HEALTHY



## 75°C Smart Sterilisation

The system automatically heats the water once every 7 days by 75°C to sterilise against diseases such as legionella. During vacation the system will automatically sterilise the day before the end of the holiday.

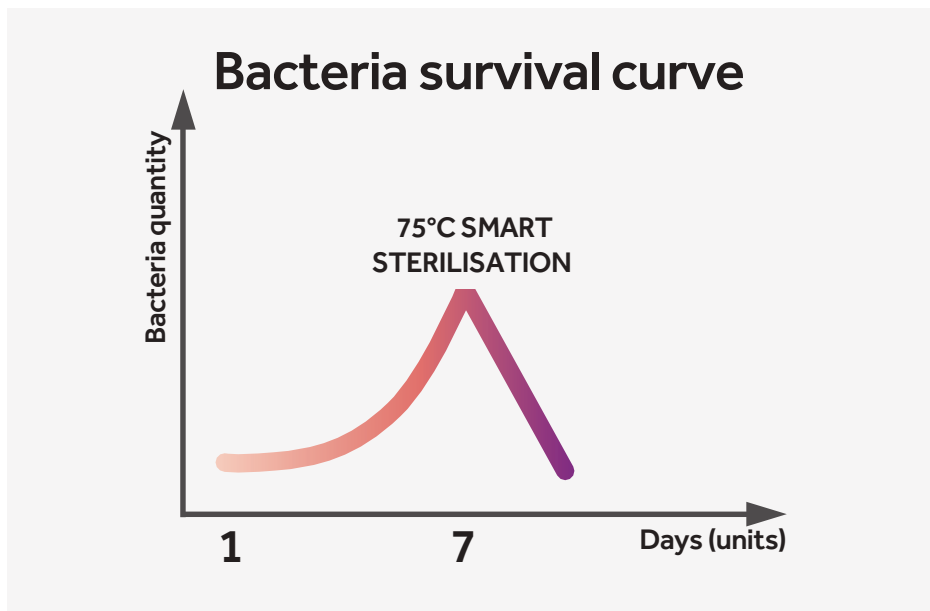

# HIGH QUALITY & DURABLE



## High-quality Enamel Tank, Longer Service Time

High-quality enamel tank, featuring an exclusive design for water heaters, offers a longer service life and stable performance.



- 1 Professional Quality**  
Haier has upgraded its enamel technology to enhance uniformity and create a high-density enamel tank that is resistant to corrosion, acid, alkali, it is extremely durable.
- 2 Advanced Formula**  
By using high-quality enamel powder and upgrading the formula we eliminate pinholes, offering superior anti-corrosion performance .
- 3 Production Technology**  
The enamel material is melted at super high temperature, the enamel layer will isolate the water and steel plate to prevent rust and scale. The tank will have longer service life.



## Anti-Freeze

The Heat pump will auto heat to 15°C when the ambient temperature reaches below 2°C and the water temperature is below 7°C

## M8 HPWH R290



HP80M8-9 - HP110M8-9 - HP150M8-9

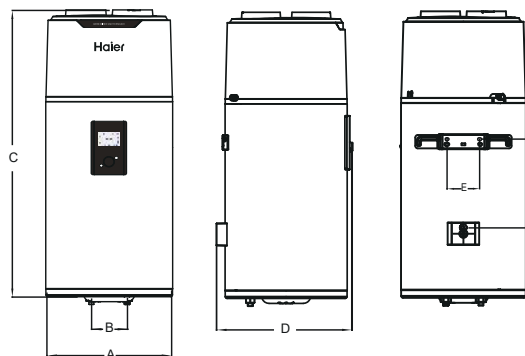

Model	A	B	C	D	E	F
HP80M8-9	492	140	1170	537	159	360
HP110M8-9	492	140	1320	537	159	360
HP150M8-9	492	140	1680	537	159	470

Unit: mm

# M8 TECHNICAL PARAMETERS

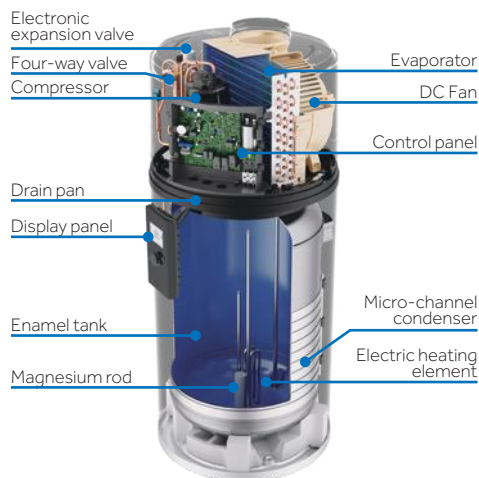

## FEATURES

- The R290 refrigerant offers excellent thermodynamic performance, allowing for higher water temperatures
- Full inverter technology and micro-channel condenser, resulting in lower energy consumption and higher heating efficiency
- Micro-channel condenser upgraded for R290 refrigerant
- Dual power heating, enables faster hot water production
- Equipped with a TFT screen and smart connectivity
- Easy installation, with simple design structure for wall mounting

Model		HP80M8-9	HP110M8-9	HP150M8-9
Tank volume	L	82	102	149
Rated voltage/ frequency	V/Hz	220-240/50	220-240/50	220-240/50
Tank rated pressure	bar	8	8	8
Corrosion protection		Magnesium rod	Magnesium rod	Magnesium rod
Energy class		A+	A+	A+
Water proof grade		IPX4	IPX4	IPX4
Performance				
Type of extraction		Ambient/Exterior	Ambient/Exterior	Ambient/Exterior
COP@7°C/EN16147		2.91	2.72	3.03
COP@14°C/EN16147		3.07	2.90	3.39
Tapping cycle		M	M	L
Power input by electric backup		1200	1200	1200
Rated power input by heat pump	W	250	250	250
Maximum power input by heat pump	W	370	370	370
Maximum power input	W	1570	1570	1570
Standby power input/Pes	W	15.3	18.7	22.5
Max volume of usable hot water at 40°C setting at 55°C	L	103.8	128.3	190
Heating up time (7°C)	h	4.44	5.64	8.62
Heating up time (14°C)	h	3.8	4.79	7.18
Default temperature setting	°C	55	55	54
Temperature setting range-with heater	°C	35-75	35-75	35-75
Maximum length of air duct	m	36	36	36
Diameter of air duct connection	mm	160	160	160
Max air quantity	m <sup>3</sup> /h	375	375	375
Max working pressure of refrigerant	MPa	1.0/3.3	1.0/3.3	1.0/3.3
Refrigerant type/weight	kg	R290/0.12	R290/0.12	R290/0.12
Noise power	dB(A)	50	50	50
Ambient temperature for use of product	°C	-7-45	-7-45	-7-45
Operating temperature of heat pump	°C	-7-45	-7-45	-7-45
Dimensions and connections				
Water inlet and outlet connection		R1/2" M Large Flow	R1/2" M Large Flow	R1/2" M Large Flow
Safety valve connection		R1/2" M	R1/2" M	R1/2" M
Drain&Water inlet connection		R1/2" M	R1/2" M	R1/2" M
Product dimensions	(mm)	492 × 537 × 1170	492 × 537 × 1320	492 × 537 × 1680
Packing dimensions without pallet	(mm)	587 × 587 × 1247	587 × 587 × 1397	587 × 587 × 1894
Packing dimensions with pallet	(mm)	/	/	587 × 587 × 1894
Net/Gross weight	kg	51/58	54/62	64/83



Micro-Channel Condenser



\*The COP and noise level data was tested in Haier lab. The COP values obtained with external air temperature of 7°C and 14°C, inlet water temperature of 10°C and set temperature of 55°C (according to EN 16147).

The data in this catalogue is purely indicative as the data may vary. Please be advised to check the accuracy of the data with the supplier before purchasing products.

## M7 HPWH R290



HP200M7-F9 - HP250M7-F9 - HP200M7C-F9 - HP250M7C-F9

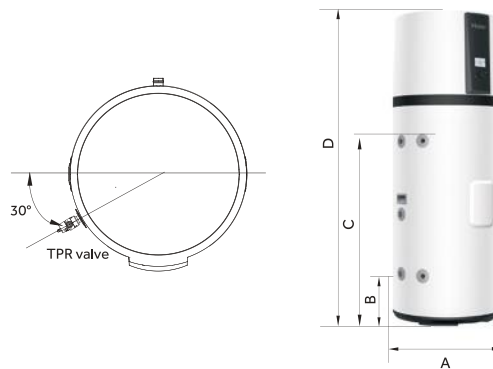

Model	A	B	C	D
HP200M7-F9	620	270	980	1694
HP250M7-F9	620	270	1275	1989
HP200M7C-F9	620	270	980	1694
HP250M7C-F9	620	270	1275	1989

Unit: mm

The data in this catalogue is purely indicative as the data may vary. Please be advised to check the accuracy of the data with the supplier before purchasing products.

# M7 TECHNICAL PARAMETERS

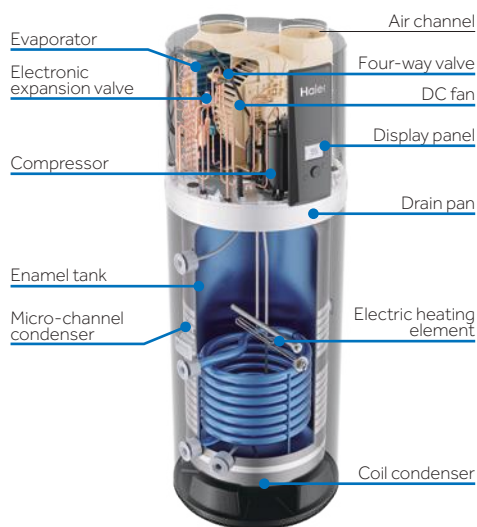

## FEATURES

- The R290 refrigerant offers excellent thermodynamic performance, allowing for higher water temperatures
- Full inverter technology and micro-channel condenser, resulting in lower energy consumption and higher heating efficiency
- Micro-channel condenser upgraded for R290 refrigerant
- Dual power heating, enables faster hot water production
- Equipped with a TFT screen and smart connectivity
- Easy install

Model		HP200M7-F9	HP200M7C-F9	HP250M7-F9	HP250M7C-F9
Total cylinder capacity	L	194	185	250	240
Rated voltage/frequency	V/Hz	220-240/50	220-240/50	220-240/50	220-240/50
Tank Max pressure	bar	7	7	7	7
Thermal insulation	mm	50	50	50	50
Corrosion protection		Magnesium rod	Magnesium rod	Magnesium rod	Magnesium rod
Energy class		A+	A+	A+	A+
Insulation protection rating		IPX4	IPX4	IPX4	IPX4
<b>Performance</b>					
COP@7°C(EN16147)		3.26	3.24	3.21	3.21
COP@14°C(EN16147)		3.50	3.50	3.45	3.45
Max air quantity	m <sup>3</sup> /h	300	300	300	300
Power input by electric backup	W	1500	1500	1500	1500
Rated power input by heat pump	W	320	320	320	320
Maximum power input by heat pump	W	535	535	535	535
Maximum power input	W	2035	2035	2035	2035
Heating water capacity	L/h	24	24	24	24
Heating up time(10°C/55°C)@7°C	h	7.8	6.71	10.51	10.09
Default temperature setting	°C	65	65	65	65
Temperature setting range-with heater	°C	35-75	35-75	35-75	35-75
Maximum temperature output for the heat pump only	°C	65	65	65	65
Refrigerant type/weight	kg	R290/0.15	R290/0.15	R290/0.15	R290/0.15
Noise power dB(A) @7°C	dB(A)	50	50	50	50
Sound pressure at 1m	dB(A)	36	36	36	36
V40 @7°C	L	234	229	313	314.4
Ambient temperature of heat pump	°C	-7-45	-7-45	-7-45	-7-45
<b>Dimensions and connections</b>					
Water inlet and outlet connection		Rp 3/4 Large Flow	Rp 3/4 Large Flow	Rp 3/4 Large Flow	Rp 3/4 Large Flow
TPR valve connection		Rp 3/4	Rp 3/4	Rp 3/4	Rp 3/4
Drain & water inlet connection		Rp 3/4	Rp 3/4	Rp 3/4	Rp 3/4
Product dimensions	(mm)	600 × 620 × 1694	600 × 620 × 1694	600 × 620 × 1989	600 × 620 × 1989
Packing dimension with pallet	(mm)	736 × 695 × 1940	736 × 695 × 1940	736 × 695 × 2250	736 × 695 × 2250
Net/gross weight	kg	86/109	96/119	98/121	107/131
Filled weight of the appliance	kg	281	282	345	348

\*The COP and noise level data was tested in Haier lab.  
The COP values obtained with external air temperature of 7°C and 14°C, inlet water temperature of 10°C and set temperature of 55°C (according to EN 16147).



# M8 + M7 INSTALLATION

## M8 - Easy Install

Smart hanger structure design, without complex actions, just fix the wall hanging board on the load-bearing wall, lift the machine, and align the back hanger with the wall hanging board to hang in, more convenient installation.

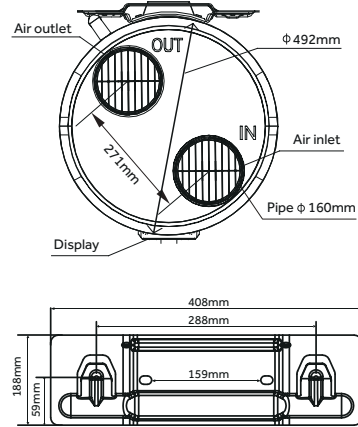
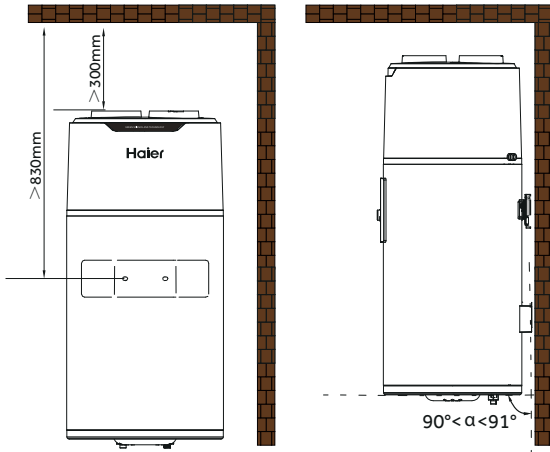

The installer needs to make sure the tank is always level.

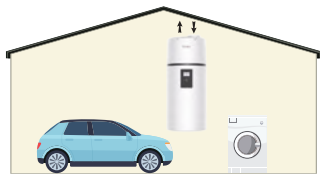

Garage or laundry room (without ducts)

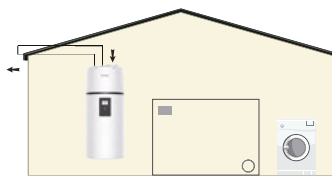

Laundry room (with one duct)

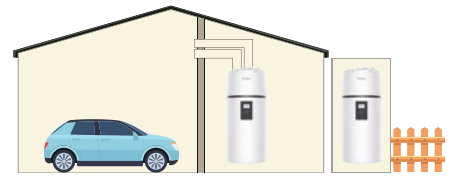

Habitable room or outside air (with two ducts)

## M7 - Easy Install

Smart and simple wall mount design for easy installation. Simply fix the wall hanging board on the load-bearing wall, lift the machine in place, and align to the back hanger to hang in.

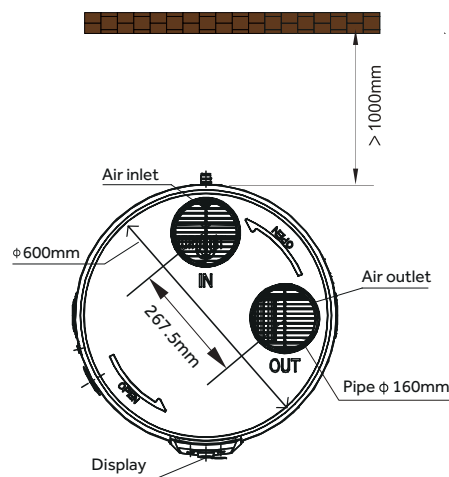

Installation in an unheated room >15m<sup>2</sup>

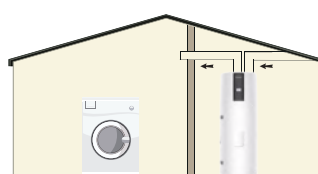

Installation with 2 ducts to the outside



Installation with 2 ducts to an unheated room >15m<sup>2</sup>

# CONNECTIONS

## CONNECTION TO SOLAR COLLECTORS

HP200M7C-F9 – HP250M7C-F9 – HP250M3C

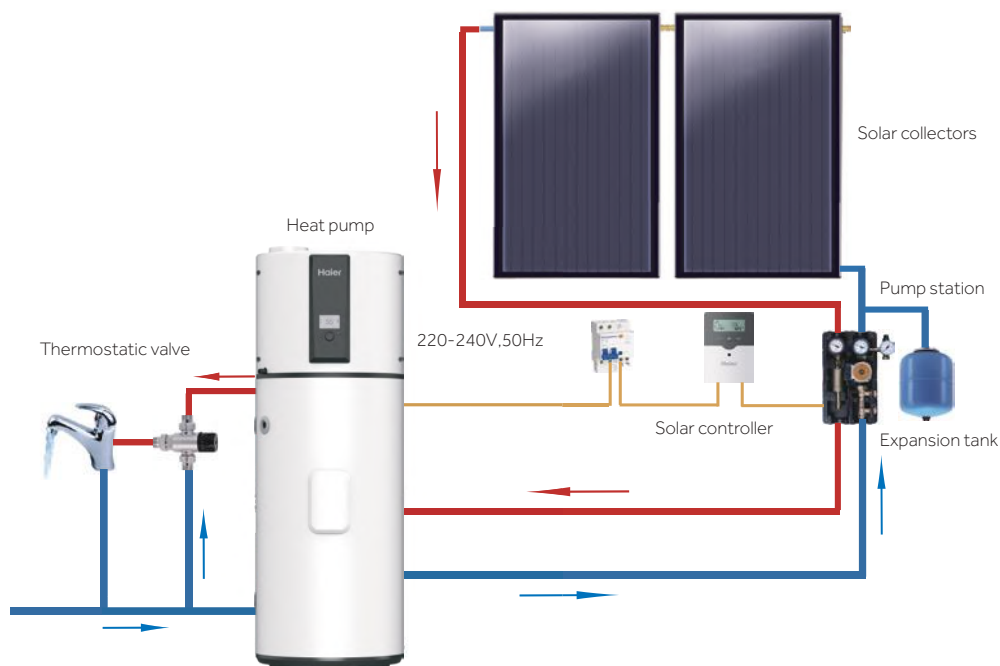

## CONNECTION TO GAS BOILER

HP200M7C-F9 – HP250M7C-F9 – HP250M3C

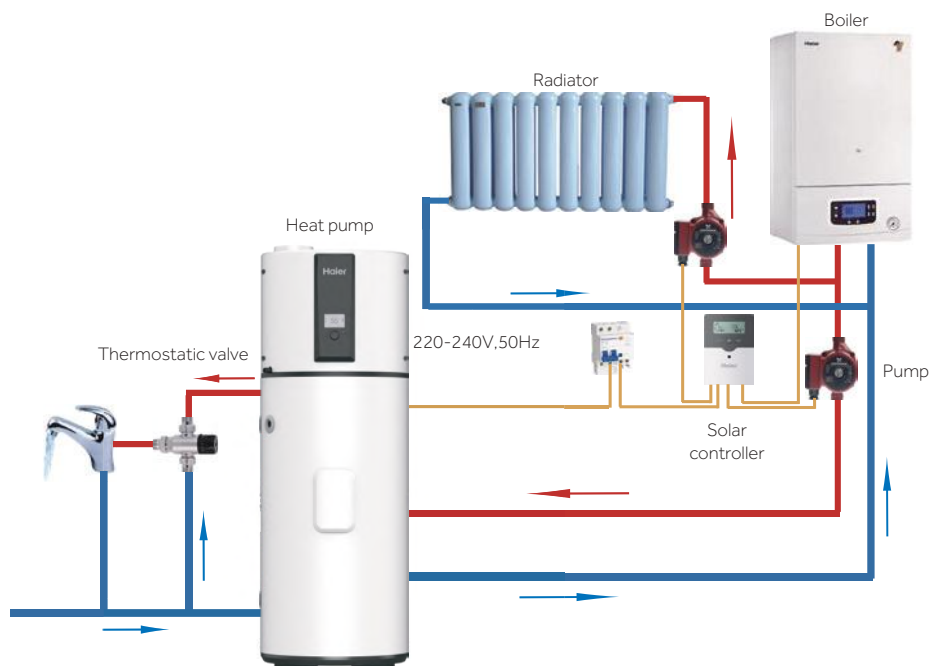

# Haier

Heating

The new name in  
**heating**

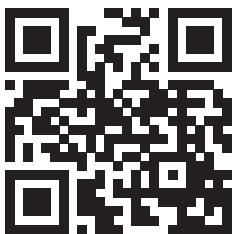

**Haier HVAC**  
haierhvac.eu

